



Spectrum Devices Corporation

Semiconductor Engineering and Manufacturing

RF & MICROWAVE TRANSISTORS HF SSB APPLICATIONS

HF50-150A

FEATURES:

- 30 MHz
- 50 Volts
- IMD -30 dB
- Common Emitter
- Gold Metallization
- $P_{out} = 150$ W PEP Min. with 14 dB Gain
- **Improved Collector-Base Breakdown Voltage: 175 Volts Min.**
- **Direct replacement for ST SD1727 (THX15)**

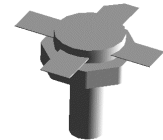

**0.500" DIAMETER
STUD PACKAGE**

DESCRIPTION:

The HF50-150A is a 50V epitaxial silicon NPN planar transistor designed primarily for SSB communications. This device utilizes emitter ballasting to achieve extreme ruggedness under severe operating conditions. The HF50-series products utilize the unique Spectrum Devices' Bipolar process which offers a 60% improvement in collector-base breakdown voltage, enhancing reliability while maintaining RF performance.

ABSOLUTE MAXIMUM RATINGS: ($T_{CASE} = 25^{\circ}C$)

Symbol	Parameter	Value	Unit
V_{CBO}	Collector-Base Voltage	175	V
V_{CEO}	Collector-Emitter Voltage	55	V
V_{EBO}	Emitter-Base Voltage	4.0	V
I_C	Device Current	10	A
P_{DISS}	Total Dissipation	233	W
T_J	Junction Temperature	+200	$^{\circ}C$
T_{STG}	Storage Temperature	-65 to +150	$^{\circ}C$

THERMAL DATA:

$R_{TH(J-C)}$	Thermal Resistance Junction-case	0.75	$^{\circ}C/W$
---------------	----------------------------------	------	---------------

ELECTRICAL SPECIFICATIONS ($T_{CASE} = 25^{\circ}C$)

DC CHARACTERISTICS

Symbol	Test Conditions	Value			Unit
		Min.	Typ.	Max.	
BV_{CBO}	$I_C = 100\text{ mA}$ $I_E = 0\text{ mA}$	175	--	--	V
BV_{CES}	$I_C = 100\text{ mA}$ $V_{BE} = 0\text{ V}$	175	--	--	V
BV_{CEO}	$I_C = 100\text{ mA}$ $I_B = 0\text{ mA}$	55	--	--	V
BV_{EBO}	$I_E = 10\text{ mA}$ $I_C = 0\text{ mA}$	4.0	--	--	V
I_{CEO}	$V_{CE} = 30\text{ V}$ $I_E = 0\text{ mA}$	--	--	5	mA
I_{CES}	$V_{CE} = 60\text{ V}$ $I_E = 0\text{ mA}$	--	--	5	mA
h_{FE}	$V_{CE} = 6\text{ V}$ $I_C = 1.4\text{ A}$	18	--	43.5	--

RF CHARACTERISTICS

Symbol	Test Conditions	Value			Unit
		Min.	Typ.	Max.	
P_{OUT}	$f = 30\text{ MHz}$ $V_{CC} = 50\text{ V}$ $I_{CQ} = 100\text{ mA}$	150	--	--	W PEP
G_P	$P_{out} = 150\text{ W PEP}$ $V_{CC} = 50\text{ V}$ $I_{CQ} = 100\text{ mA}$	14	--	--	dB
IMD*	$P_{out} = 150\text{ W PEP}$ $V_{CC} = 50\text{ V}$ $I_{CQ} = 100\text{ mA}$	--	--	-30	dBc
η_C	$P_{out} = 150\text{ W PEP}$ $V_{CC} = 50\text{ V}$ $I_{CQ} = 100\text{ mA}$	40	--	--	%
C_{OB}	$f = 1\text{ MHz}$ $V_{CB} = 50\text{ V}$	--	--	220	pF

*Conditions $f_1 = 30.00\text{MHz}$ $f_2 = 30.001\text{MHz}$

TYPICAL PERFORMANCE

Power Output vs Power Input

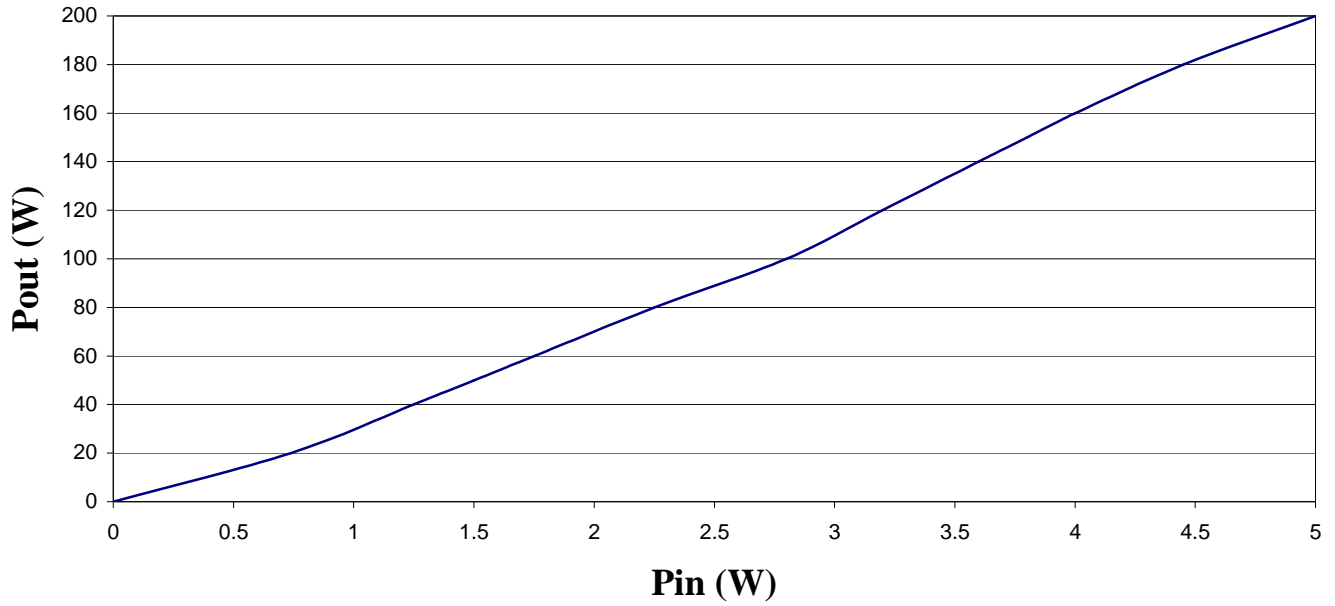

Collector Efficiency vs. Power Output

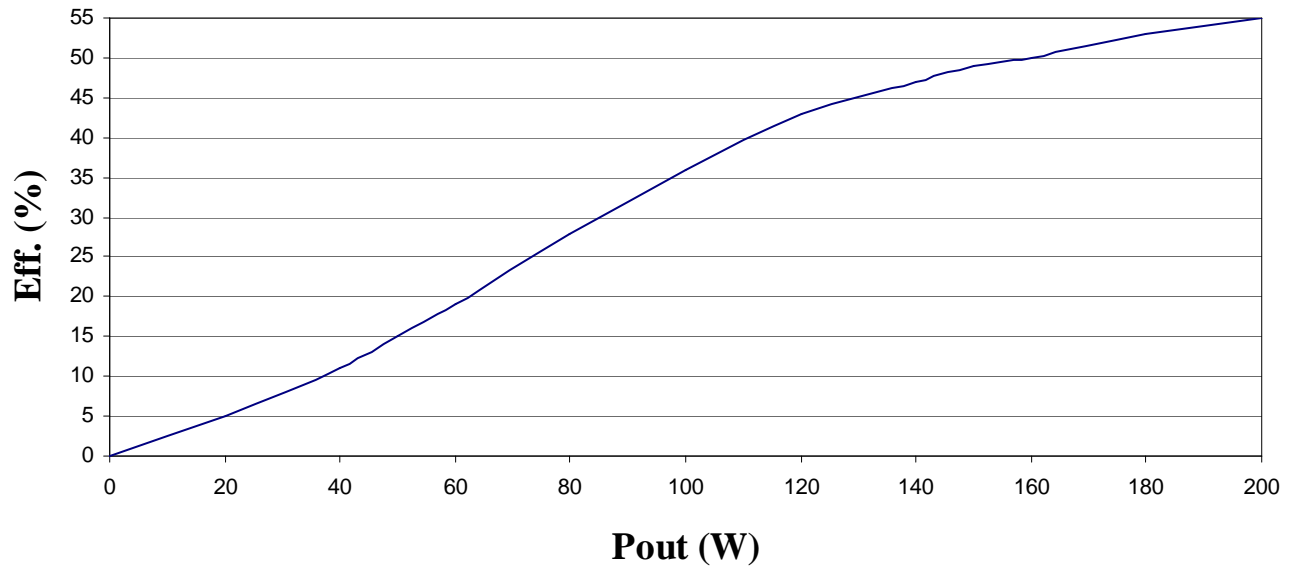

PCB BOARD LAYOUT

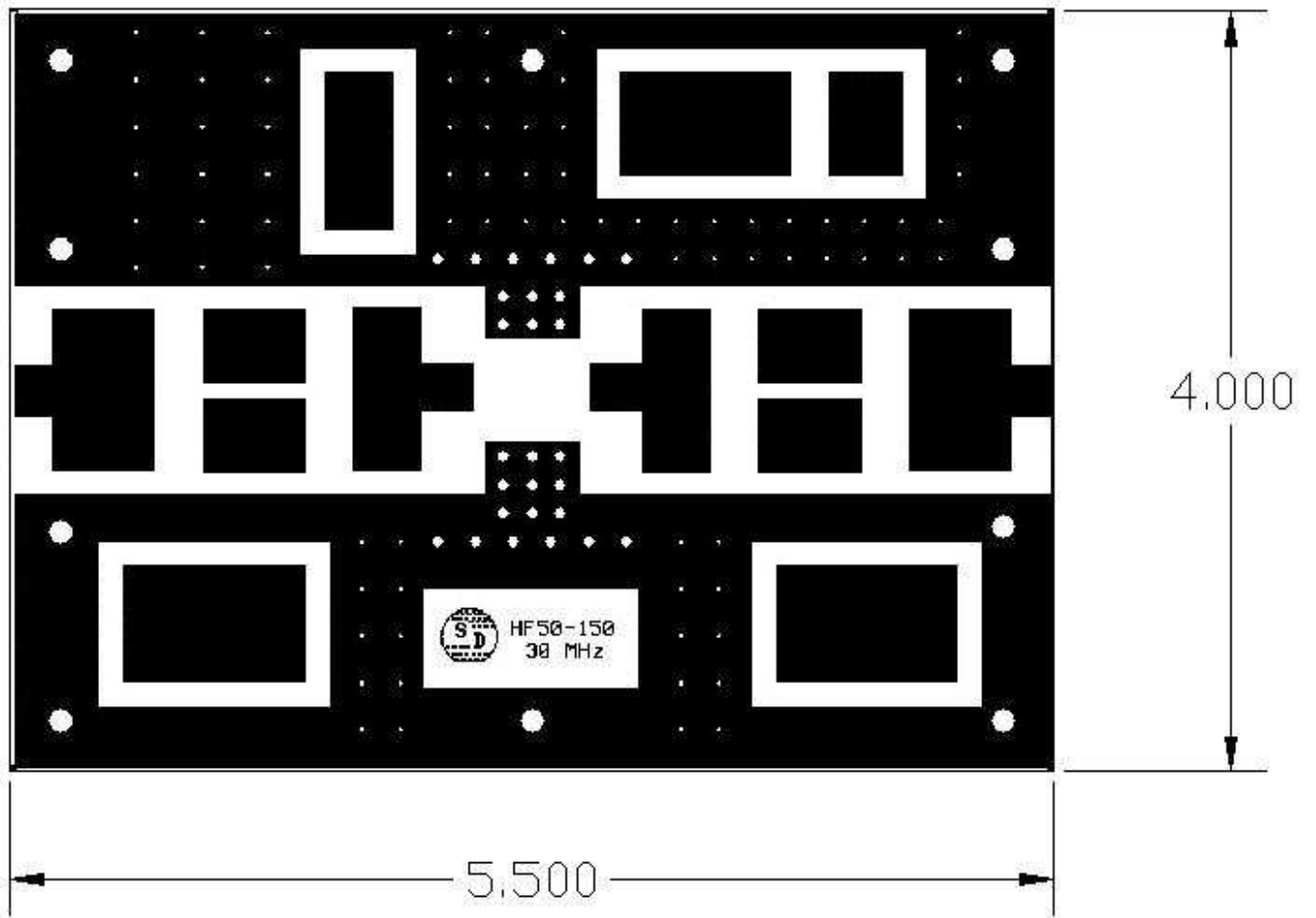

PACKAGE MECHANICAL DATA

SOE-500-Stud

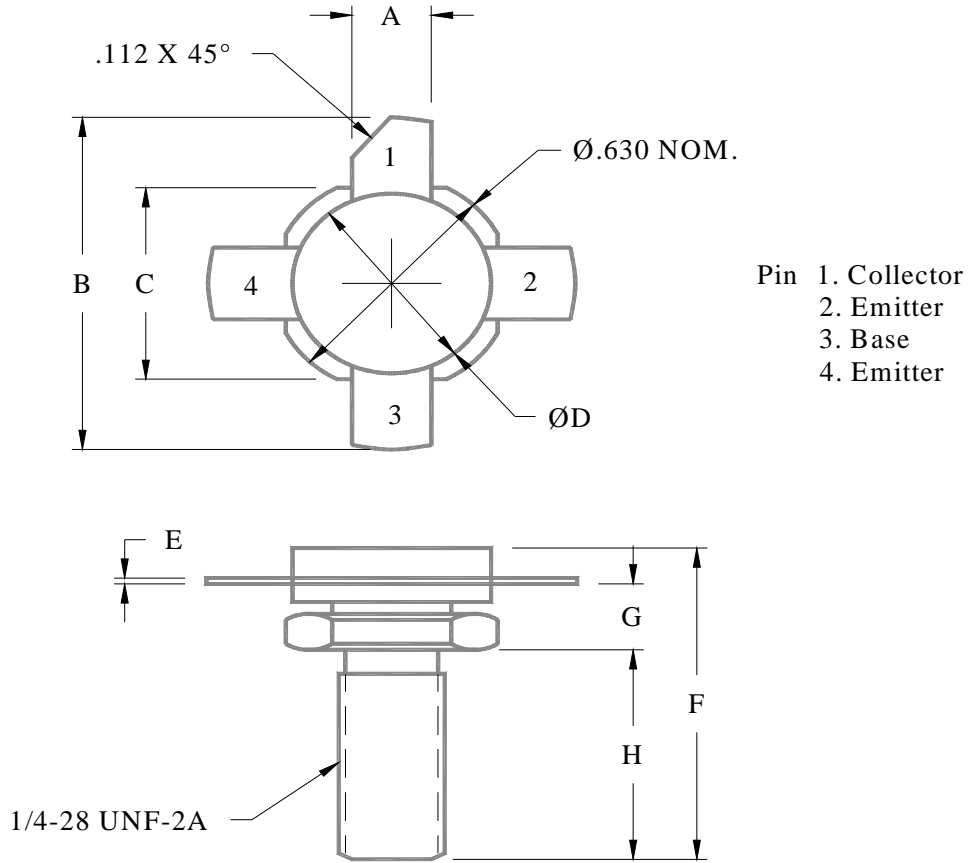

	Minimum Inches/MM	Maximum Inches/MM		Minimum Inches/MM	Maximum Inches/MM
A	.220/5.59	.230/5.84	E	.003/0.08	.007/0.18
B		1.050/26.67	F		.810/20.57
C	.545/13.84	.555/14.10	G	.185/4.70	.198/5.03
D	.495/12.57	.505/12.83	H	.497/12.62	.530/13.46

DISCLAIMER

Spectrum Devices Corporation reserves the right to change, without notice, the specifications and information contained herein. Spectrum Devices Corporation believes the information contained within this data sheet to be accurate and reliable. However, no responsibility is assumed by Spectrum Devices Corporation for its use or for any infringement of patents or other rights of third parties which may result from its use. No license is granted by implication or otherwise under any patent or patent rights of Spectrum Devices Corporation. Spectrum Devices Corporation makes no warranty, representation, or guarantee regarding the suitability of its products for any particular purpose. "Typical" parameters are the average values expected by Spectrum Devices Corporation and are provided for information purposes only. These values can and do vary in different applications, and actual performance can vary over time. All operating parameters should be validated by customer's technical personnel for each application.

Life Support Applications

These products are not designed, intended, or authorized for use in applications intended for surgical implant or to support or sustain life, in which the failure of the Spectrum Devices Corporation product could result in personal injury or death. Spectrum Devices Corporation customers using or selling these products in such applications do so at their own risk and agree to indemnify Spectrum Devices Corporation from any damages resulting from improper use or sale.

Visit our website at www.spectrumdevices.com or contact our facility directly at
Spectrum Devices Corp., 2880 Bergey Road, Suite C, Hatfield, PA 19440.
Phone 215-997-7870 or FAX 215-997-7828