



Spectrum Devices Corporation

Semiconductor Engineering and Manufacturing

RF & MICROWAVE TRANSISTORS VHF MOBILE APPLICATIONS

VHF12-40

FEATURES:

- 160 MHz
- 13.6 Volts
- Common Emitter
- P_{out} = 40W Min. with 9.0 dB Gain
- Replacement for SD1275-01

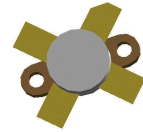

0.380" DIAMETER
SOE PACKAGE

DESCRIPTION:

The VHF12-40 is a 13.6V Class C epitaxial silicon NPN planar transistor designed primarily for VHF communications. The VHF12-40 utilizes an emitter ballasted die geometry to withstand severe load mismatch conditions

ABSOLUTE MAXIMUM RATINGS: ($T_{CASE} = 25^{\circ}C$)

Symbol	Parameter	Value	Unit
V_{CBO}	Collector-Base Voltage	36	V
V_{CEO}	Collector-Emitter Voltage	18	V
V_{CES}	Collector-Emitter Voltage	36	V
V_{EBO}	Emitter-Base Voltage	4.0	V
I_C	Device Current	8.0	A
P_{DISS}	Power Dissipation	70	W
T_J	Junction Temperature	+200	$^{\circ}C$
T_{STG}	Storage Temperature	-65 to +150	$^{\circ}C$

THERMAL DATA:

$R_{TH(J-C)}$	Thermal Resistance Junction-case	1.2	$^{\circ}C/W$
---------------	----------------------------------	-----	---------------

ELECTRICAL SPECIFICATIONS ($T_{CASE} = 25^{\circ}C$)

DC CHARACTERISTICS

Symbol	Test Conditions	Value			Unit
		Min.	Typ.	Max.	
BV_{CES}	$I_C = 15mA$ $V_{BE} = 0 mA$	36	--	--	V
BV_{CEO}	$I_C = 50mA$ $I_B = 0 mA$	18	--	--	V
BV_{EBO}	$I_E = 5 mA$ $I_C = 0 mA$	4.0	--	--	V
I_{CBO}	$V_{CB} = 15V$ $I_E = 0 mA$	--	--	5	mA
h_{FE}	$V_{CE} = 5V$ $I_C = 250mA$	20	--	--	--

RF CHARACTERISTICS

Symbol	Test Conditions	Value			Unit
		Min.	Typ.	Max.	
P_{OUT}	$f = 160 MHz$ $P_{IN} = 5.0W$ $V_{CC} = 13.6V$	40	--	--	W
G_P	$f = 160 MHz$ $P_{IN} = 5.0W$ $V_{CC} = 13.6V$	9	--	--	dB
C_{OB}	$f = 1 MHz$ $V_{CB} = 15 V$	--	95	--	pF

TYPICA



PACKAGE MECHANICAL DATA

SOE-380

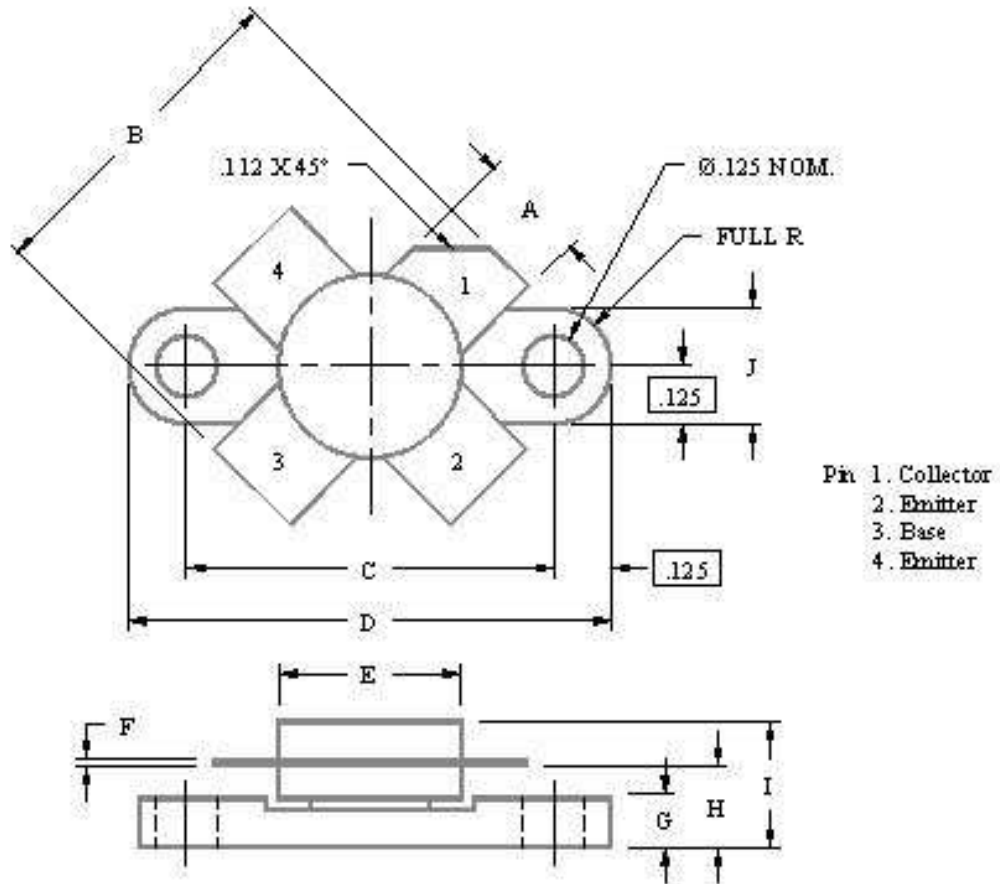

	Minimum Inches/MM	Maximum Inches/MM		Minimum Inches/MM	Maximum Inches/MM
A	.220/5.59	.230/5.84	G	.085/2.16	.105/2.67
B	.785/19.94		H	.160/4.06	.180/4.57
C	.720/18.29	.730/18.54	I	.260/7.11	
D	.970/24.64	.980/24.89	J	.240/6.10	.255/6.48
E	.385/9.78				
F	.004/0.10	.006/0.15			

Visit our website at www.spectrumdevices.com or contact our facility directly at Spectrum Devices Corp., 2880 Bergey Road, Suite C, Hatfield, PA 19440. Phone 215-997-7870 or FAX 215-997-7828

DISCLAIMER

Spectrum Devices Corporation reserves the right to change, without notice, the specifications and information contained herein. Spectrum Devices Corporation believes the information contained within this data sheet to be accurate and reliable. However, no responsibility is assumed by Spectrum Devices Corporation for its use or for any infringement of patents or other rights of third parties which may result from its use. No license is granted by implication or otherwise under any patent or patent rights of Spectrum Devices Corporation. Spectrum Devices Corporation makes no warranty, representation, or guarantee regarding the suitability of its products for any particular purpose. “Typical” parameters are the average values expected by Spectrum Devices Corporation and are provided for information purposes only. These values can and do vary in different applications, and actual performance can vary over time. All operating parameters should be validated by customer’s technical personnel for each application.

Life Support Applications

These products are not designed, intended, or authorized for use in applications intended for surgical implant or to support or sustain life, in which the failure of the Spectrum Devices Corporation product could result in personal injury or death. Spectrum Devices Corporation customers using or selling these products in such applications do so at their own risk and agree to indemnify Spectrum Devices Corporation from any damages resulting from improper use or sale.

Visit our website at www.spectrumdevices.com or contact our facility directly at
Spectrum Devices Corp., 2880 Bergey Road, Suite C, Hatfield, PA 19440.
Phone 215-997-7870 or FAX 215-997-7828